

Manual brake bending machines

FSBM – Manual brake bending machines with foot pedal operated workpiece clamping

- ▶ Foot pedal operated workpiece clamping leaves both hands free for feeding in the material
- ▶ Different tool variants available E, S2, HS2 and HSG
- ▶ The powerful servo-cylinder facilitates bending
- ▶ Passageway between top + bottom beam up to 25 mm
- ▶ Self-lubricating plain bearings
- ▶ Clamping pressure on the top beam easily adjustable through knurled screws
- ▶ Material thickness setting through knurled screw
- ▶ Adjustable stop for bending angle



FSBM 2020-12 E

With segmented acute bending tools, full-width bending rail and full-width support bed

Model	Max. working width	Max. sheet thickness* Steel 235 N/mm ²	Max. sheet thickness VA steel	Max. bending angle	Weight	Dimensions L x W x H	Art. no.
FSBM 1020-25 E	1 020 mm	2.5 mm	1.5 mm	135°	290 kg	1 350 x 800 x 1 130 mm	3772125
FSBM 1020-20 S2	1 020 mm	2.0 mm	1.2 mm	135°	325 kg	1 350 x 800 x 1 130 mm	3772102
FSBM 1020-20 HSG**	1 020 mm	2.0 mm	1.2 mm	150°	360 kg	1 280 x 620 x 1 200 mm	3770103
FSBM 1270-20 E	1 270 mm	2.0 mm	1.2 mm	135°	340 kg	1 600 x 800 x 1 130 mm	3772127
FSBM 1270-20 HS2	1 270 mm	2.0 mm	1.2 mm	135°	370 kg	1 600 x 800 x 1 130 mm	3772128
FSBM 1520-15 E	1 520 mm	1.5 mm	0.9 mm	135°	415 kg	1 850 x 770 x 1 130 mm	3772129
FSBM 2020-12 E	2 020 mm	1.2 mm	0.7 mm	135°	540 kg	2 290 x 820 x 1 180 mm	3772130

*Performance data for material with tensile strength of 235 N/mm²; bending performance stainless steel (VA) = factor 0.75;

bending performance aluminium = 1.2; tempered top tools are necessary for bending stainless steel (VA);**Segments have a hardness of HRC24-26



FSBM 1270-20 E
With segmented acute bending tools, full-width bending rail and full-width support bed



FSBM 1020-20 S2
With segmented acute bending tools, segmented bending rail and full-width support bed



FSBM 1020-20 HSG
With high, segmented top beam, segmented support bed and segmented bending beam as standard

Dimensions E series:

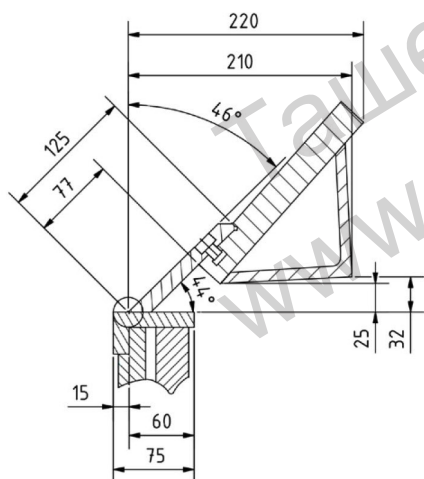

Dimensions S2 / HS2 series:

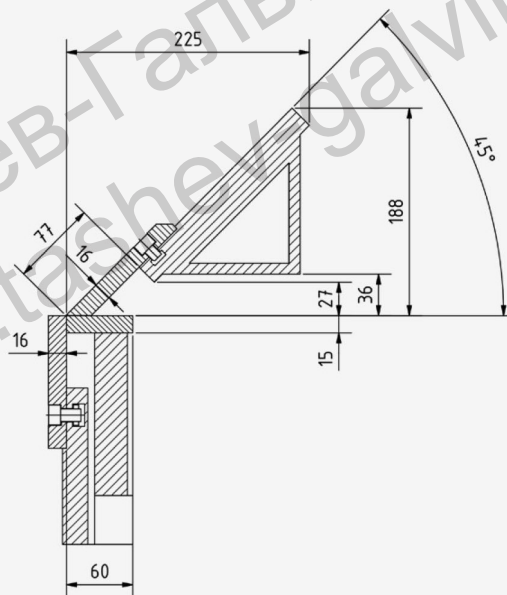

Dimensions HSG series:

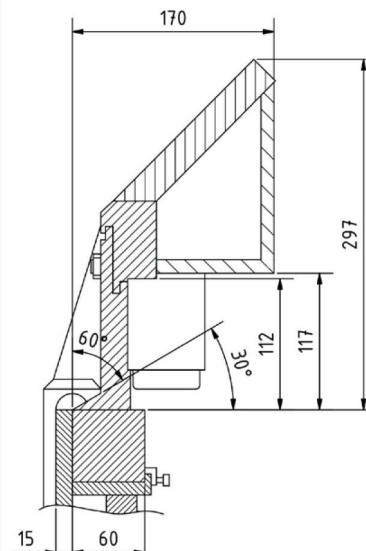

Max. passageway between top tool and support bed 25mm

Type	Segmentation
FSBM 1020-25 E	25-30-35-40-45-50-75-100-150-200-270 mm
FSBM 1020-20 S2	25-30-35-40-45-50-75-100-150-200-270 mm
FSBM 1020-20 HSG	25-30-35-40-45-50-75-100-150-200-270 mm
FSBM 1270-20 E	25-30-35-40-45-50-75-100-150-200-250-270 mm
FSBM 1270-20 HS2	25-30-35-40-45-50-75-100-150-200-250-270 mm
FSBM 1520-15 E	25-30-35-40-45-50-75-100-150-200-250-270 mm
FSBM 2020-12 E	25-30-35-40-45-50-75-100-150-200-250-270-500 mm

Option	Art. no.
Tempered segments FSBM 1020-25 E*	3772702
Tempered segments FSBM 1020-20 S2*	3772701
Tempered segments FSBM 1270-20 E*	3772703
Tempered segments FSBM 1270-20 HS2*	3772703
Tempered segments FSBM 1520-15 E*	3772704

*Only the top tool is tempered

Accessories	Art. no.
Rear stop up to 300 mm New (fits 3772102, 3772125, 3772127, 3772128)	3772720